



**2024 BELT SANDER RACES**

March 8 - 10, 2024 | **LOCATION:** RED DEER HOME SHOW, WESTERNER PARK

**SPONSORS**



Proceeds go to the BILD-CAres Funds supporting local organizations and charities.

**SIGN UP AND GET YOUR BELT SANDER READY TO RACE!**

RACE TEAM NAME:
COMPANY NAME:
PHONE:
EMAIL:
TEAM NAME(s) 4 People per Team (1 driver and 3-person pit crew):
CLASS: <input type="checkbox"/> Stock <input type="checkbox"/> Modified

RACE TEAM REGISTRATION (includes 4 weekend event passes)	\$50.00	
SPONSORSHIP (\$100 for Banner, \$250 for Lane or other contact our office)		
Banners to be supplied by sponsor and must be under 4' tall and 10' long. Lane sponsorship will be created and supplied by the Red Deer Home Show. All other must be approved by Administration.	Sub-Total	\$
	5% GST (R1078788852)	\$
	<b>TOTAL</b>	
<b>Method of Payment:</b>		
<input type="checkbox"/> Cheque (BILD Members only. Payable to BILD-CA) <input type="checkbox"/> Amex <input type="checkbox"/> MasterCard <input type="checkbox"/> Visa		
CC#: _____ CVV Code: _____ Expiry: _____		

Signature: \_\_\_\_\_ Date: \_\_\_\_\_

### Stock Class

- Belt Sander must be store bought unmodified sanders by an established Manufacturer/Brand.
- No Modifications or substitutions to mechanical, belt or electrical components.
- Track Guides and Wheelie Bars allowed and encouraged. (See Track & Guide)
- Decoration are allowed and encouraged but keep they should not drop below the track as they could interfere with the side rails.

### Modified Class

- This is an open category the fastest sander through alterations.
- Belt Sander must propel itself with conventional sanding belt only.
- Modifications and Substitutions allowed to Motor, Drive System, Electricals, etc.
- Track Guides and Wheelie Bars allowed and encouraged. (See Track & Guide.)
- Decoration are allowed and encouraged but keep they should not drop below the track as they could interfere with the side rails.
- All open gearing must have guards to prevent injury.

This is a public event and safety must be top of mind so we can enjoy years to come.

### Track

- Two plywood tracks, 1 foot apart. Sanders race side by side.
- Inside dimension of track is 7 3/4" wide, with 1 7/8" high sidewalls.
- Race length is 30' long. There is a 20' run-out track after the finish line.
- Race entries must fit into track, and run on track surface.

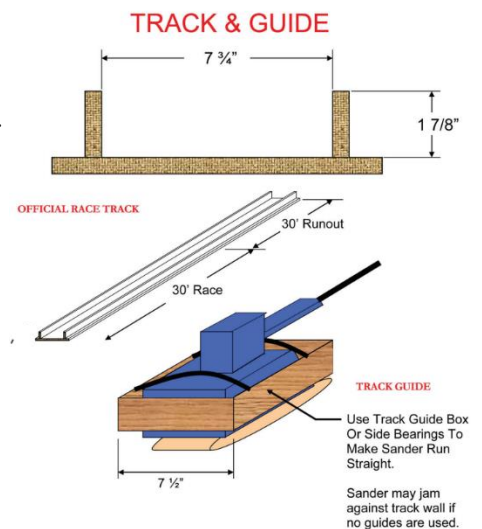

### Power

- Standard 120 Volts A.C.
- Race entry must plug into standard 3 prong extension cord.
- Modified Sander must run on supplied power.

### Sanding Belt

- Race entry must run on unaltered, store-bought sanding belt.
- Any size or grit of sanding belt acceptable, provided belt fits in track.

### Racing

- Race Official's decision is final.
- Race entry owners are responsible for tracking entry belt before each race.
- Race entry owners are responsible for ensuring sander fits into track.
- Race entry owners are responsible for any sander decorations.
- Race entry owners are responsible for all risks or damage to their sander.
- Once sander is placed on track, it cannot be touched, adjusted, or interfered with.
- Race Official aligns entries at starting line and plugs in power cord.
- Race Official is responsible for making sure switch is on.
- Race will be replayed if switch was not on, or in Race Official's discretion, and other unfair situation occurred.
- Race Officials collect sanders at the end of track and return them to their owners.
- Sander is disqualified if it stops, jumps track, flips, or does not finish for any reason.
- Racing is conducted on a double elimination basis for each race entry, unless Race Official announces alternative format.

### Best Decorated / Worst Decorated

- Decorating sanders will be a highlight of the rave event. All teams are encouraged to decorate their race entries in whatever way they want. Make sure no decorations fall below height of the side rails.